

A 25 Mbps, 12.4 pJ/Bit DQPSK Backscatter Wireless Uplink for the NeuroDisc BCI

James Rosenthal, Eleftherios Kampionakis, Apoorva Sharma, Matthew S. Reynolds

Electrical & Computer Engineering, University of Washington

Introduction

Multi-day neural plasticity experiments in non-human primate (NHP) models require wireless neural recording with a high rate uplink and minimal power consumption [1].

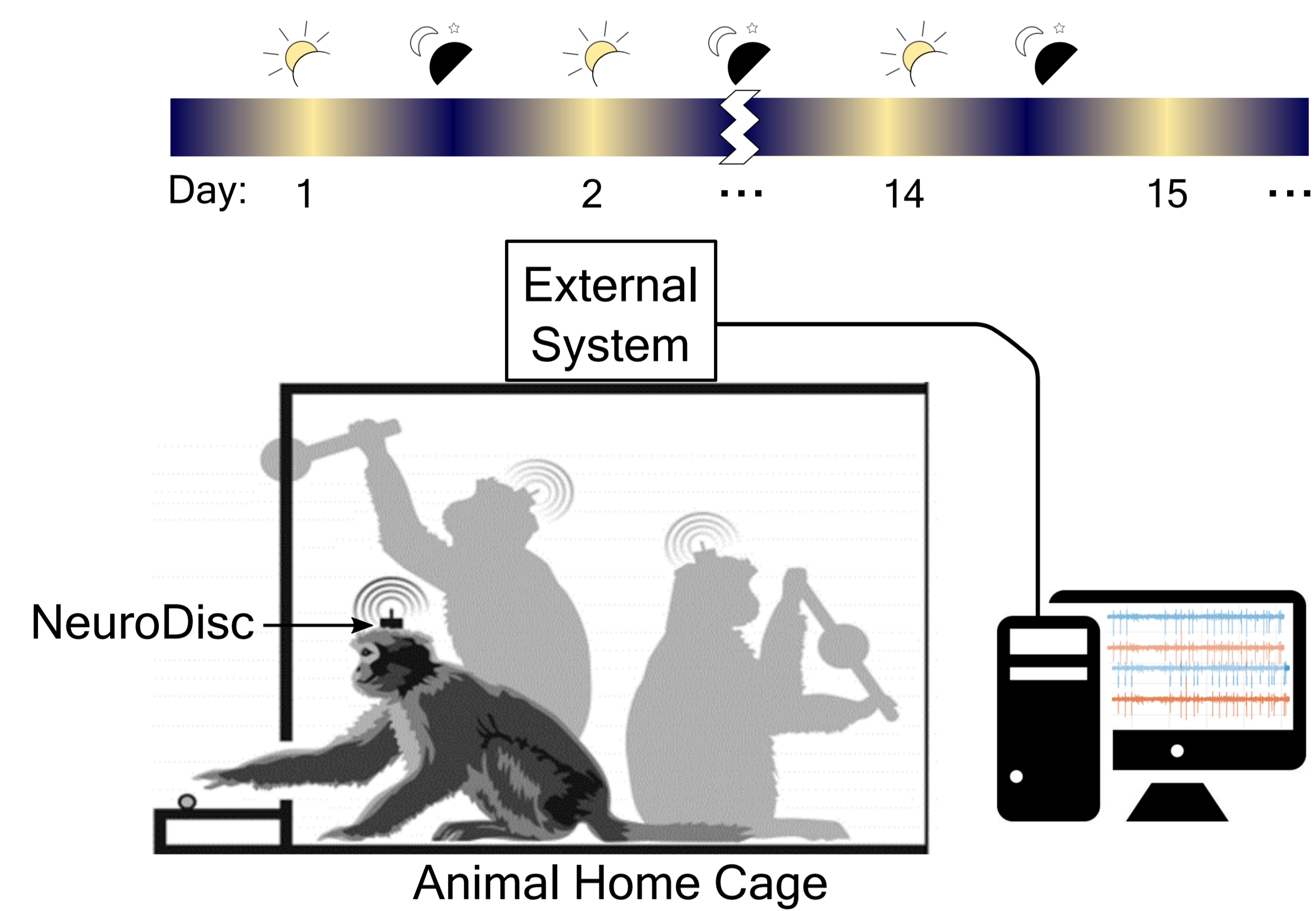

We introduce a **25 Mbps differential quadrature phase-shift keying (DQPSK) backscatter wireless uplink** for the NeuroDisc brain-computer interface (BCI), operating in the 902-928 MHz industrial, scientific, and medical (ISM)-band.

The backscatter uplink consumes **310 μW** , yielding a communication energy efficiency of **12.4 pJ/bit**.

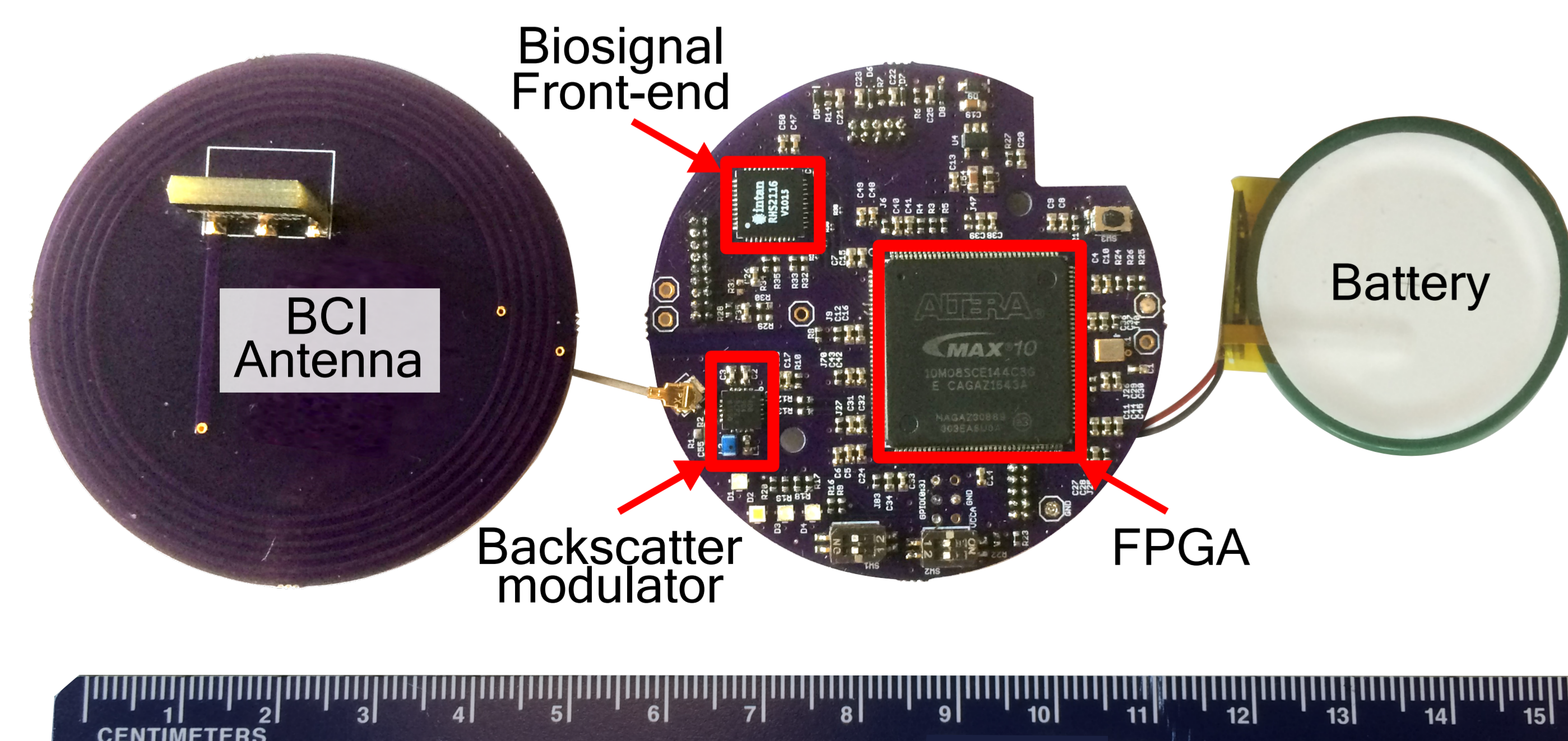

Approach

Backscatter communication leverages an asymmetric architecture that moves the power-hungry RF synthesizer and amplifier from the BCI to the External Device.

NeuroDisc (DQPSK Backscatter): 12.4 pJ/bit and 25 Mbps

SD Card: 1.25 nJ/bit and 80 Mbps

IEEE 802.11n Wi-Fi: 4 nJ/bit and 150 Mbps

Bluetooth Low Energy (BLE) 4.0: 10 nJ/bit and 1 Mbps

Ultra-Wide Band [2]: ≥ 150 pJ/bit and 200 Mbps

The NeuroDisc selectively reflects an incident carrier wave supplied by the External System by connecting its antenna to one of four load impedances via an RF switch.

With four discrete loads, we implement DQPSK modulation, improving bandwidth and efficiency relative to binary modulation schemes [3].

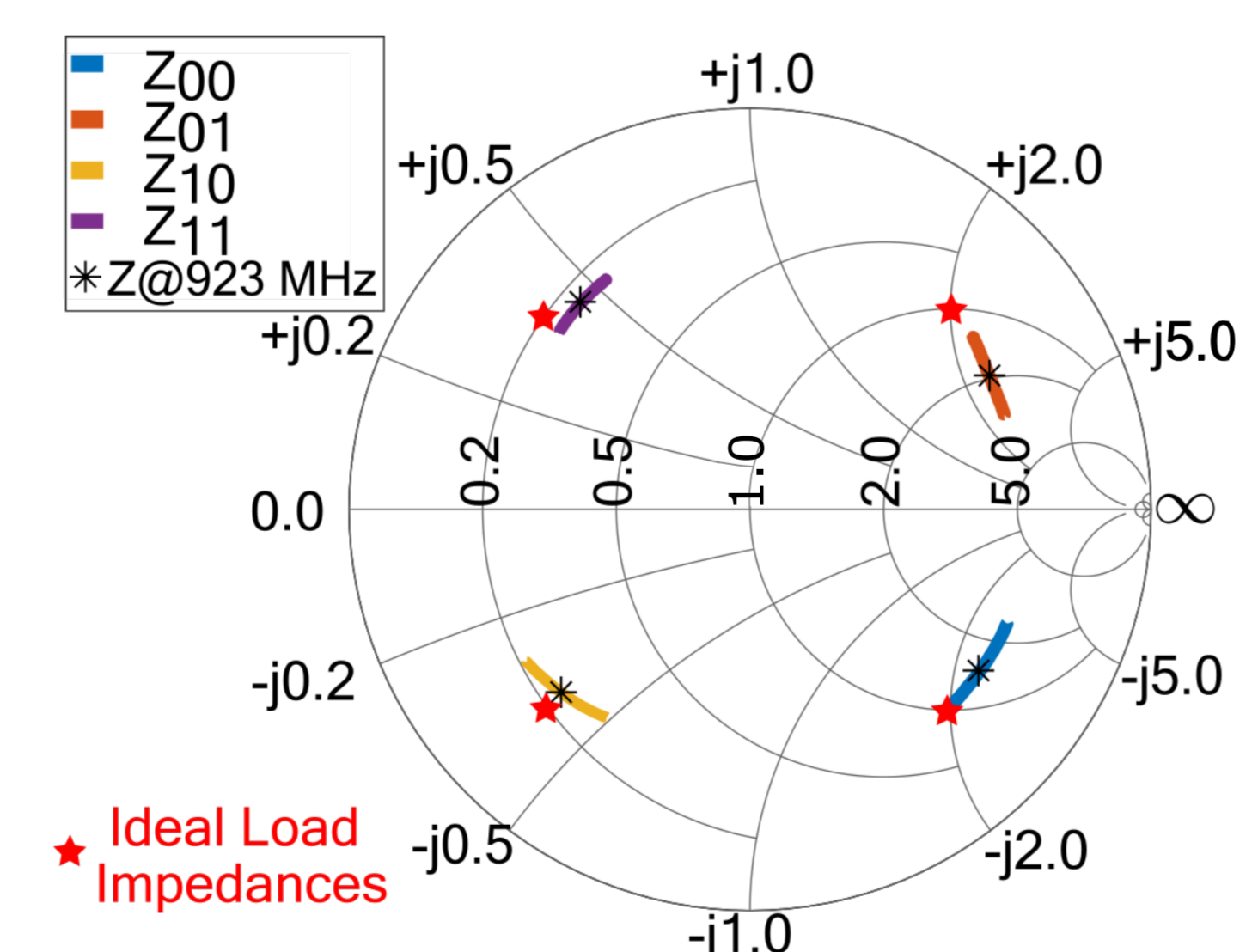
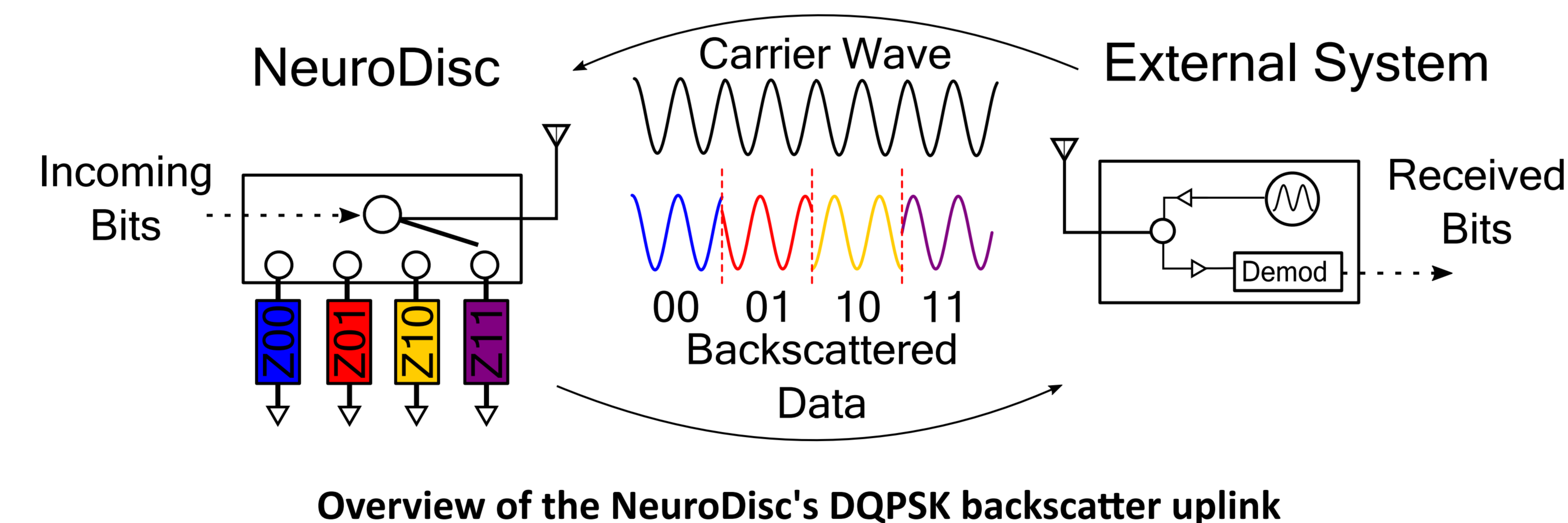

Measured impedances of the four switch states on the NeuroDisc

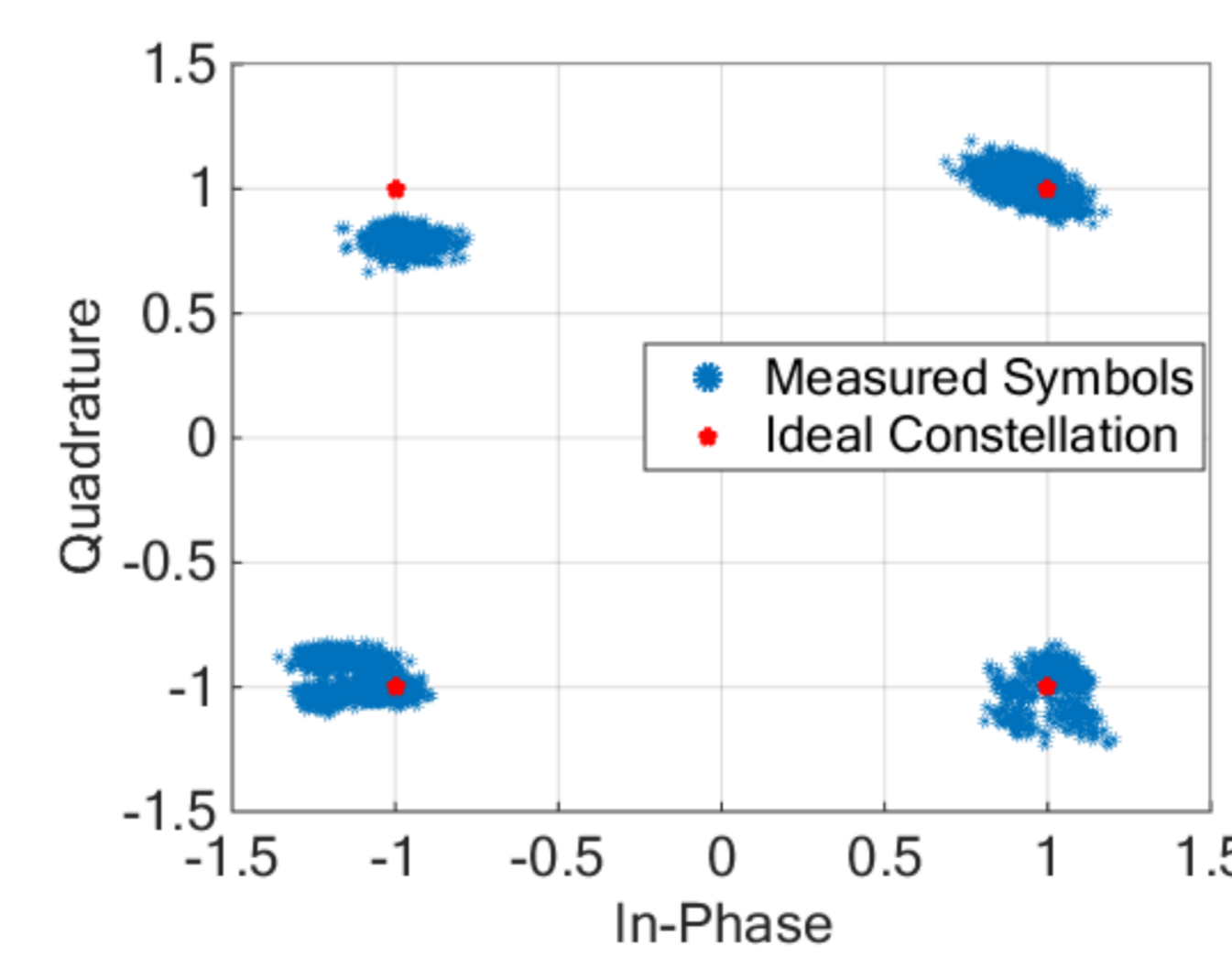

Received symbol constellation at the External System

In Vitro & In Vivo Results

In Vitro: Good agreement was observed between wireless data uplinked by the NeuroDisc and data saved to a local SD card by the NeuroChip-3 BCI [1]. Pre-recorded neural signals were used and each BCI recorded data at 20 kSps with 16-bit resolution.

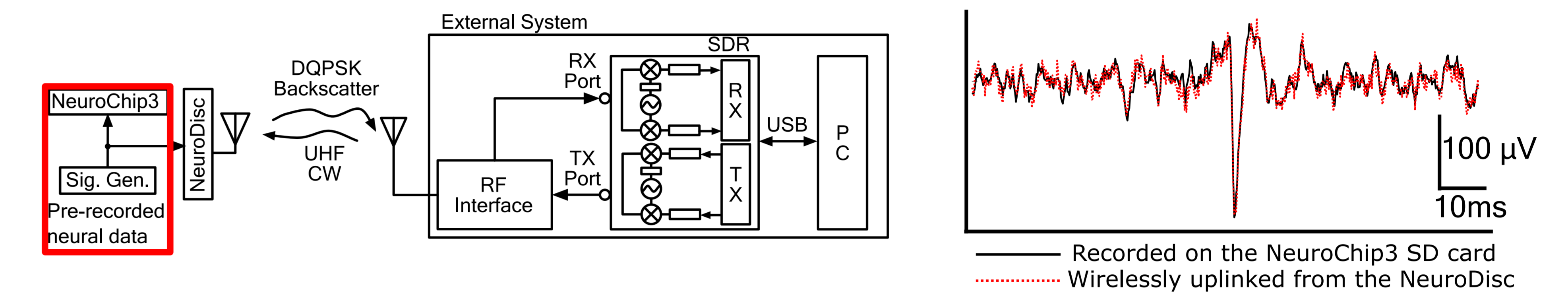

Experimental setup for *in vitro* recordings

Comparison of the signals recorded by both BCIs

In Vivo: 16 channels of neural ensemble activity were simultaneously recorded from a sedated NHP (*Macaca nemestrina*) at 20 kSps/channel with 16-bit resolution/channel and uplinked at 25 Mbps.

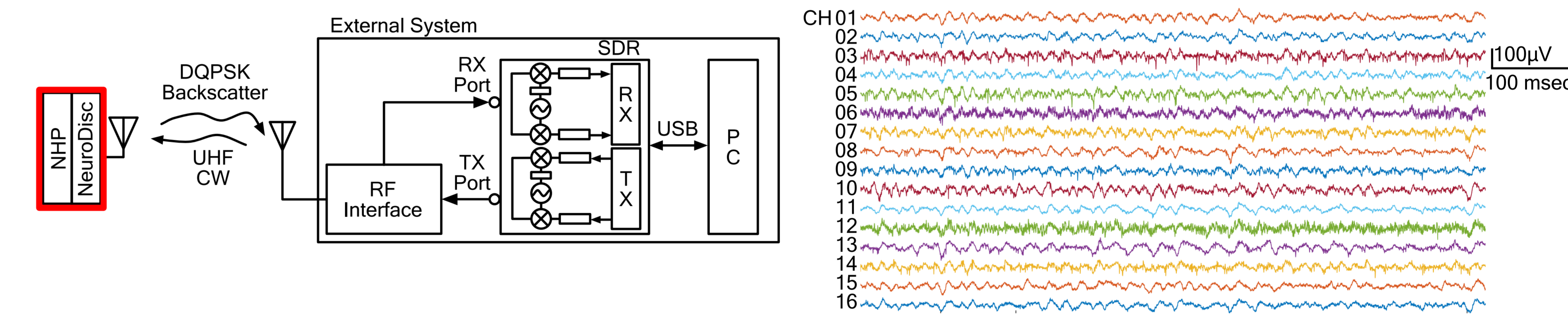

Experimental setup for *in vivo* recordings

Uplinked data from 16 neural channels

Updates & Future Work

- Added a BLE-compatible backscatter uplink mode [4]
- Integrate the NeuroDisc system onto a single integrated circuit
- Addition of wireless power transfer for battery charging
- Long-duration *in vivo* testing

References

- [1] S. Zanos, et al., "The Neurochip-2: an autonomous head-fixed computer for recording and stimulating freely behaving monkeys," *IEEE Trans. Neural Syst. Rehabil. Eng.*, vol. 19, no. 4, pp. 427-435, 2011.
- [2] M. Yin, et al., "Wireless neurosensor for full-spectrum electrophysiology recordings during free behavior," *Neuron*, vol. 84, no. 6, pp. 1170-1182, December 2014.
- [3] S. J. Thomas, et al., "Quadrature amplitude modulated backscatter in passive and semipassive UHF RFID systems," *IEEE Trans. on Microwave Theory and Techniques*, vol. 60, no. 4, pp.1175-1182, April 2012.
- [4] J. Rosenthal and M.S. Reynolds, "A 158 pJ/bit 1.0 Mbps Bluetooth Low Energy (BLE) compatible backscatter system for wireless sensing," *IEEE Wireless Sensor Networks Conference*, 2019. (accepted)

Acknowledgements

All *in vivo* measurements procedures were conducted under approval by the UW IACUC. The project described was supported in part by Award Number EEC-1028725 from the National Science Foundation, as well as by the National Science Foundation Graduate Research Fellowship Program under Grant No. DE-1762114 (J.R.). The content is solely the responsibility of the authors and does not necessarily represent the official views of the National Science Foundation.